

CSE4203: Computer Graphics
Chapter – 7 (part - C)
Viewing

Mohammad Imrul Jubair

Outline

- Perspective projection matrix

Homogeneous Coordinates (1/3)

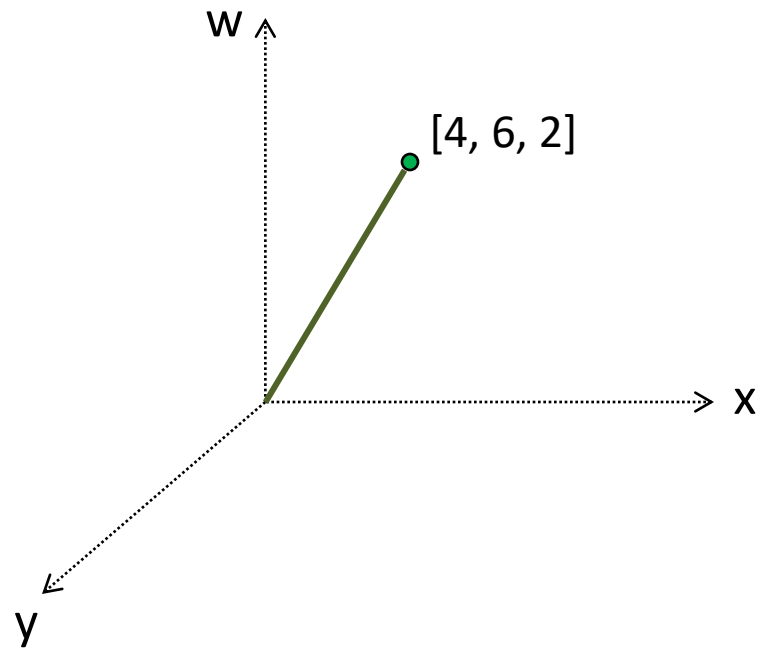

$$[x, y, w] \rightarrow [4, 6, 2]$$

Homogeneous Coordinates (2/3)

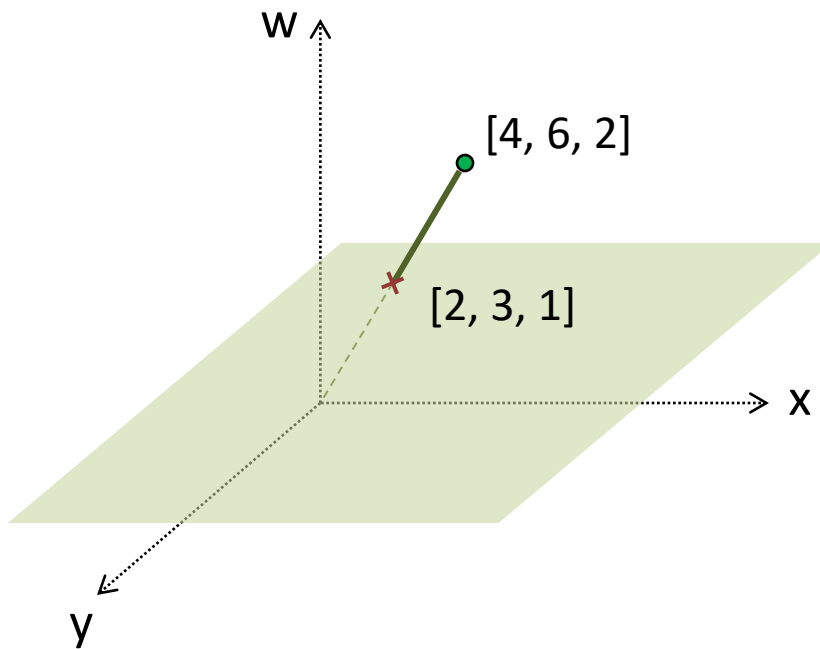

$$[x, y, w] \rightarrow [x/w, y/w, 1]$$

Homogeneous Coordinates (3/3)

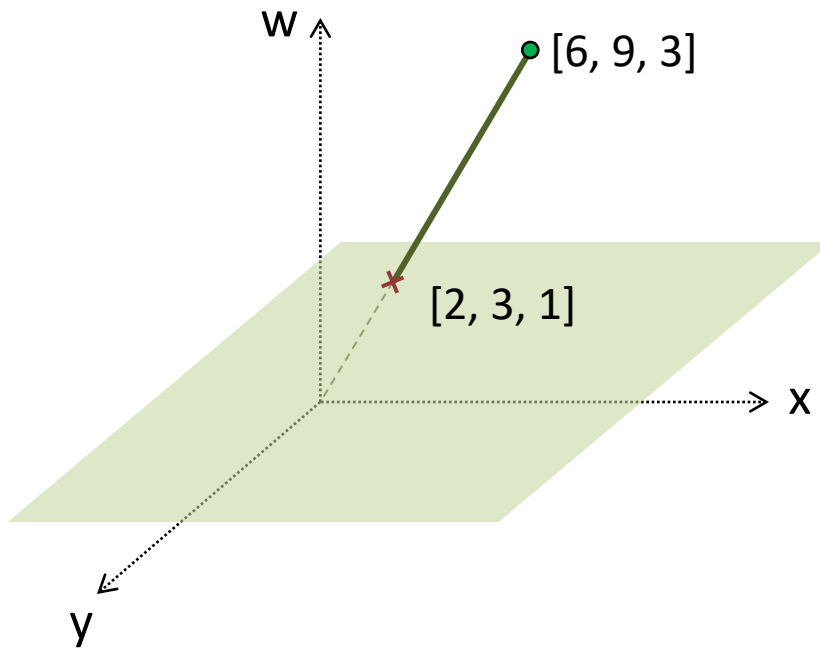

$$[x, y, w] \rightarrow [x/w, y/w, 1]$$

$$\begin{bmatrix} x \\ y \\ w \end{bmatrix} \sim \begin{bmatrix} x/w \\ y/w \\ w/w \end{bmatrix} \sim \begin{bmatrix} x/w \\ y/w \\ 1 \end{bmatrix}$$

Key property of perspective

- Size of an object on the screen is proportional to $1/z$

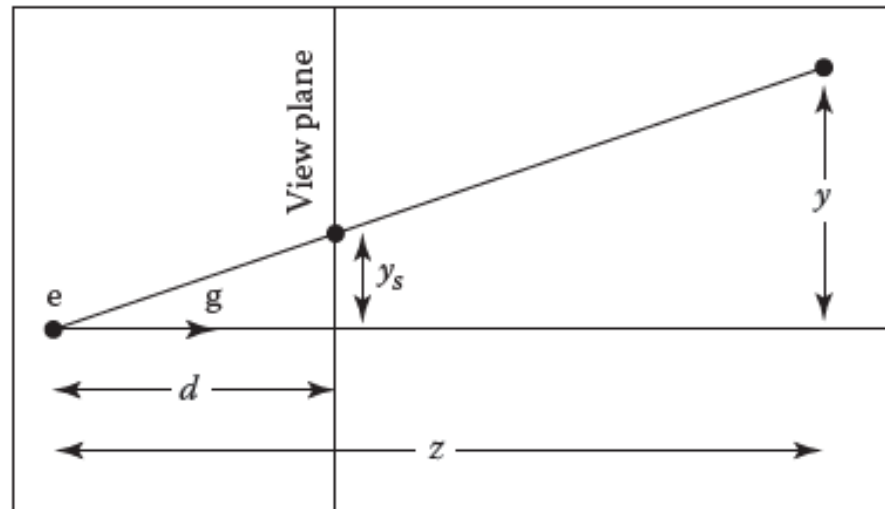

Perspective Projection (1/22)

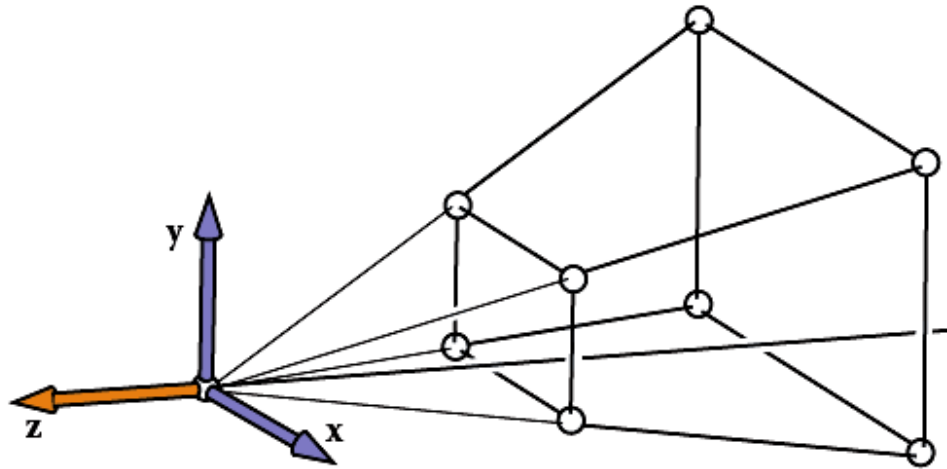

perspective view volume
(viewing frustum)

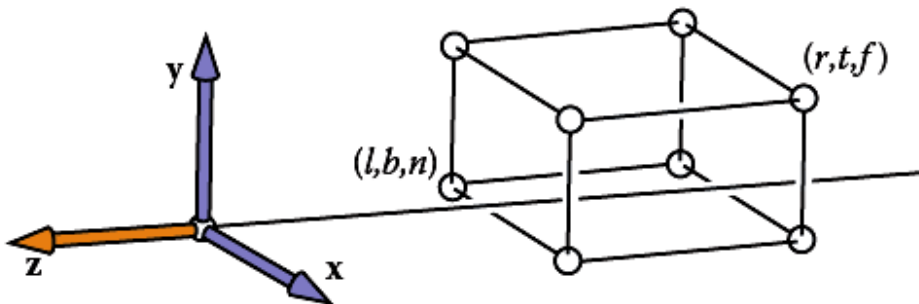

orthographic view volume

Perspective Projection (2/22)

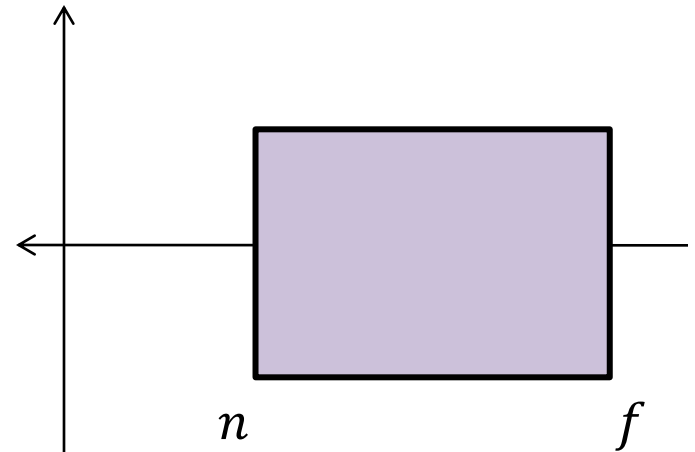
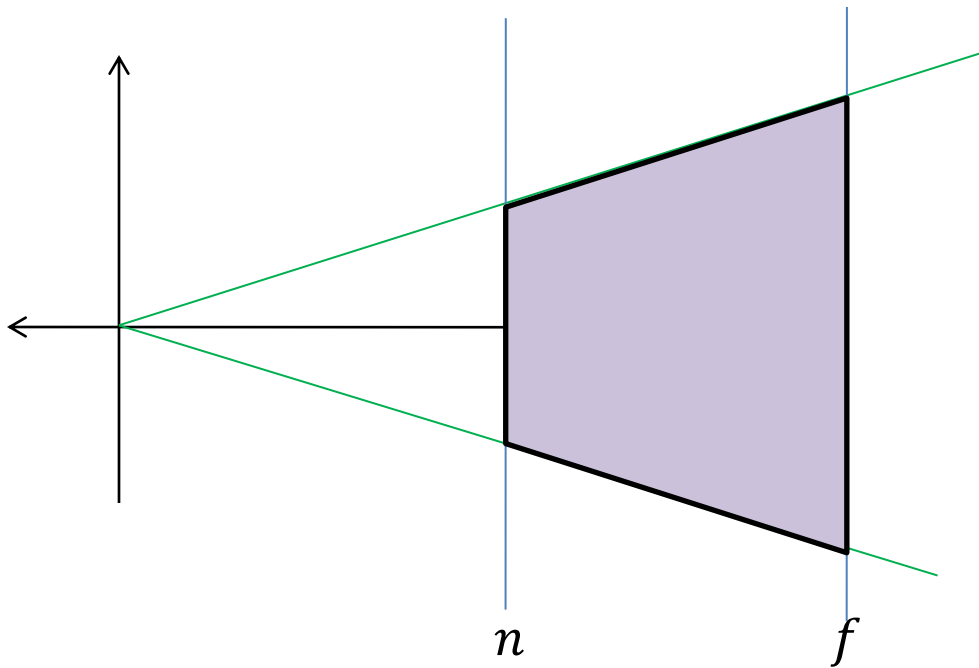
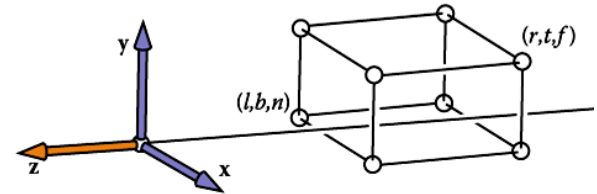
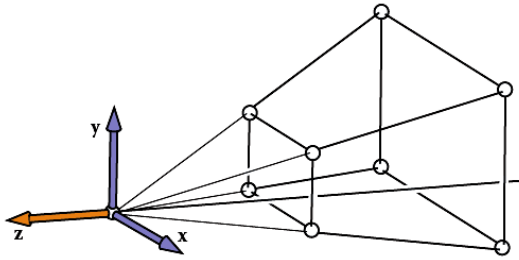

Perspective Projection (3/22)

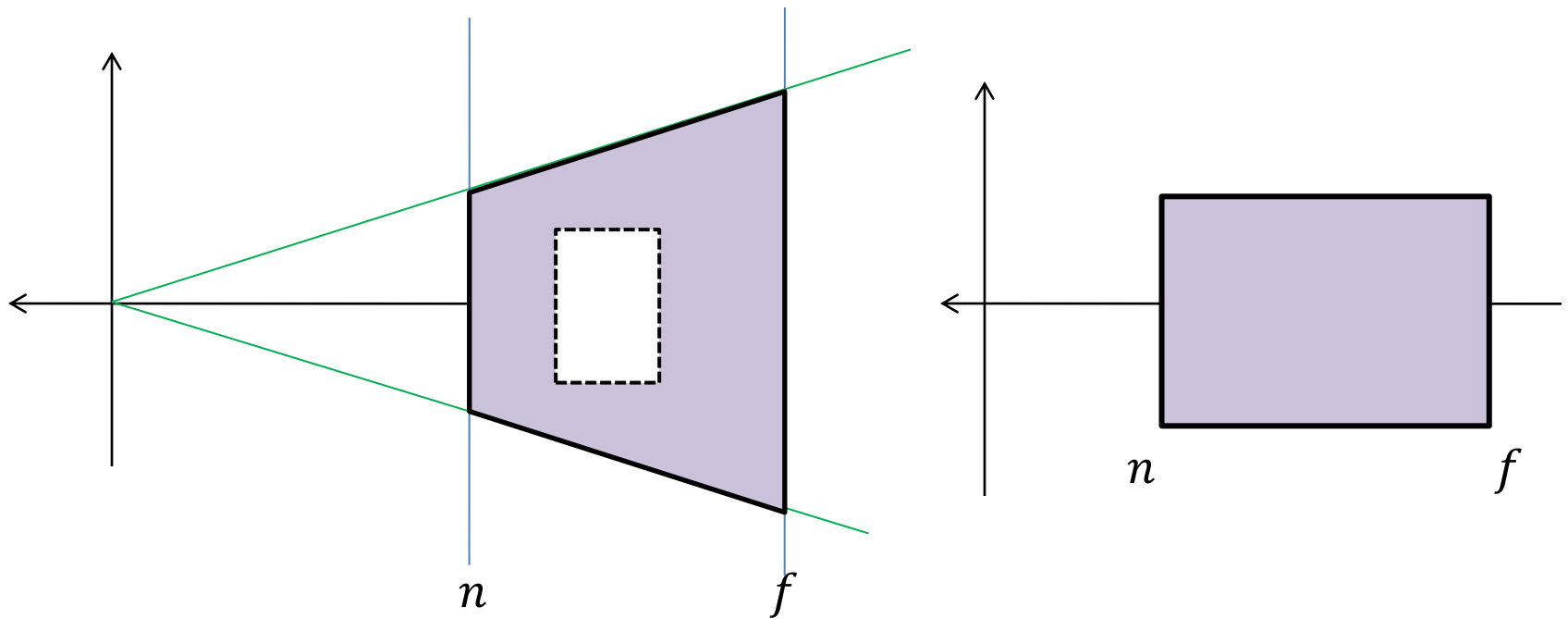

Perspective Projection (5/22)

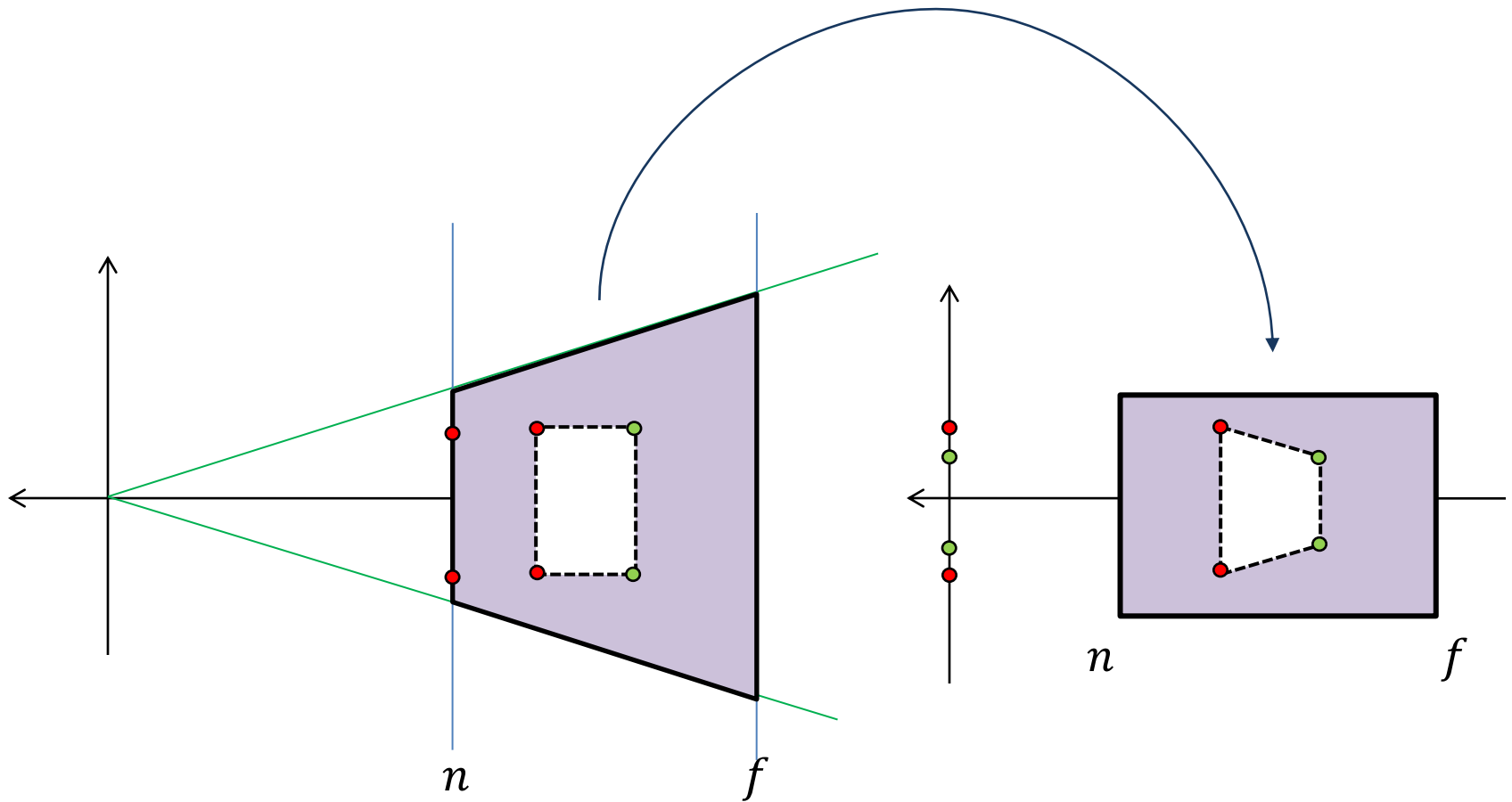

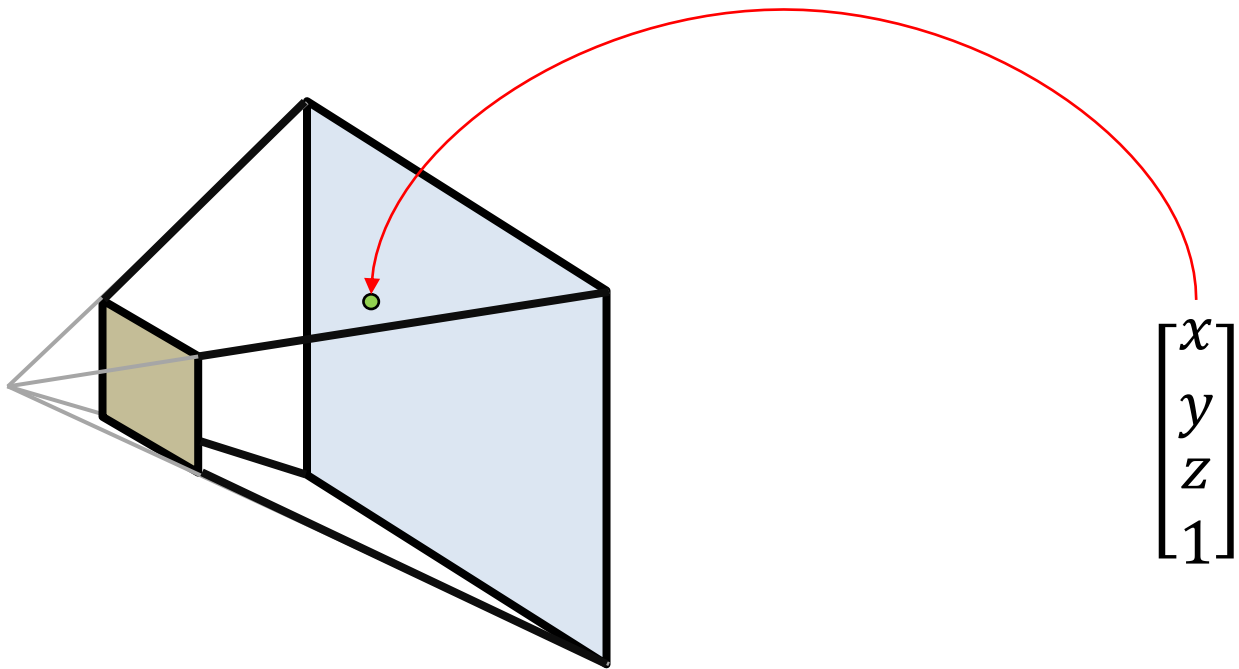

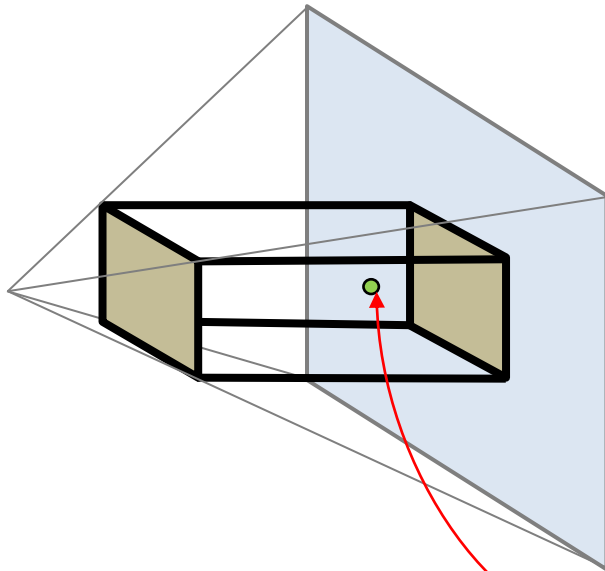

$$\begin{bmatrix} x' \\ y' \\ z' \\ 1 \end{bmatrix} = \mathbf{M} * \begin{bmatrix} x \\ y \\ z \\ 1 \end{bmatrix}$$

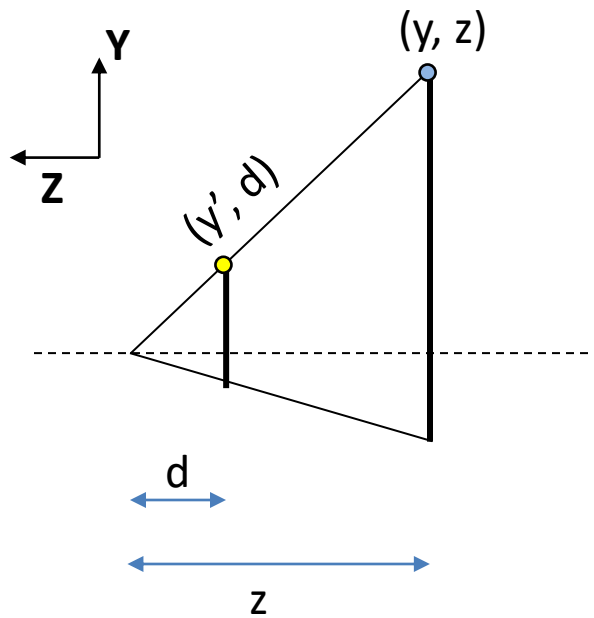

For 1D:

$$\frac{y'}{d} = \frac{y}{z}$$

$$y' = dy/z$$

$$\begin{bmatrix} d & 0 & 0 \\ 0 & 1 & 0 \end{bmatrix} \begin{bmatrix} y \\ z \\ 1 \end{bmatrix}$$

$$= \begin{bmatrix} dy \\ z \end{bmatrix} \sim \begin{bmatrix} dy/z \\ 1 \end{bmatrix} = \begin{bmatrix} y' \\ 1 \end{bmatrix}$$

For 2D:

$$y' = dy/z$$

$$x' = dx/z$$

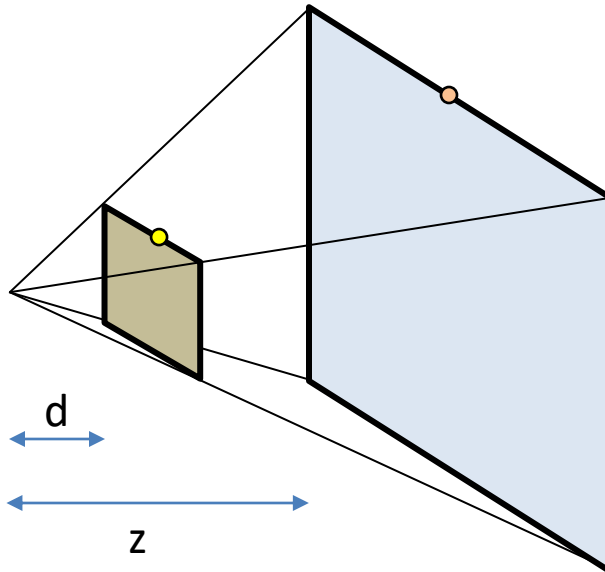

$$\begin{bmatrix} d & 0 & 0 & 0 \\ 0 & d & 0 & 0 \\ 0 & 0 & 1 & 0 \end{bmatrix} \begin{bmatrix} x \\ y \\ z \\ 1 \end{bmatrix}$$

$$= \begin{bmatrix} dx \\ dy \\ z \end{bmatrix} \sim \begin{bmatrix} dx/z \\ dy/z \\ 1 \end{bmatrix} = \begin{bmatrix} x' \\ y' \\ 1 \end{bmatrix}$$

For 3D:

$$y' = dy/z$$

$$x' = dx/z$$

$$z' = z$$

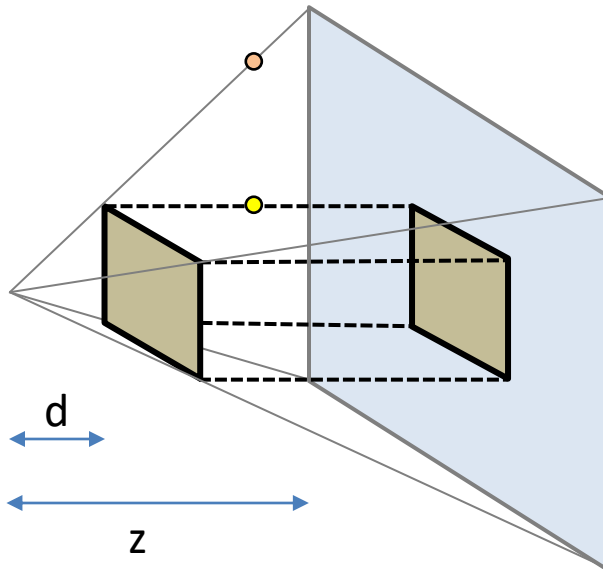

There will be always division by z ,
so $z' = z$ is not possible.

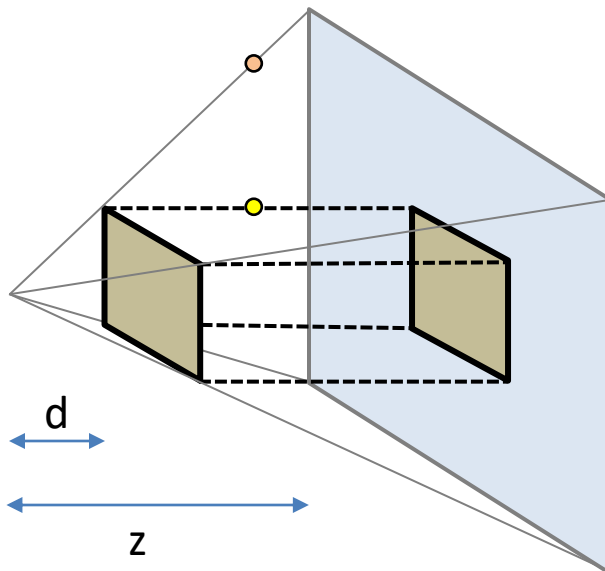

Scaling z with a and translating it by b .

For 3D:

$$y' = dy/z$$

$$x' = dx/z$$

$$z' = (az + b)/z$$

$$\begin{bmatrix} d & 0 & 0 & 0 \\ 0 & d & 0 & 0 \\ 0 & 0 & a & b \\ 0 & 0 & 1 & 0 \end{bmatrix} \begin{bmatrix} x \\ y \\ z \\ 1 \end{bmatrix}$$

$$= \begin{bmatrix} dx \\ xy \\ az + b \\ z \end{bmatrix} \sim \begin{bmatrix} dx/z \\ dy/z \\ (az + b)/z \\ 1 \end{bmatrix} = \begin{bmatrix} x' \\ y' \\ z' \\ 1 \end{bmatrix}$$

Perspective Projection (17/22)

$$\begin{bmatrix} d & 0 & 0 & 0 \\ 0 & d & 0 & 0 \\ 0 & 0 & a & b \\ 0 & 0 & 1 & 0 \end{bmatrix} \begin{bmatrix} x \\ y \\ z \\ 1 \end{bmatrix} = \begin{bmatrix} dx/z \\ dy/z \\ (az+b)/z \\ 1 \end{bmatrix}$$

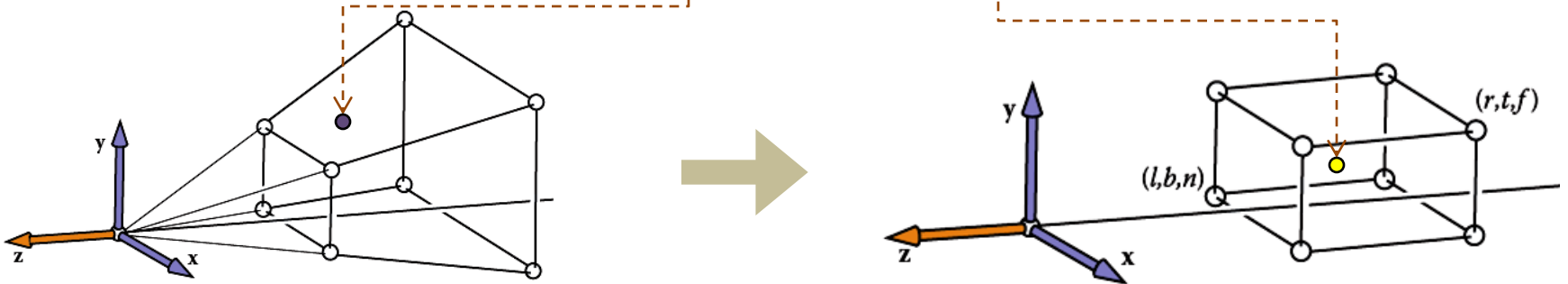

Perspective Projection (20/22)

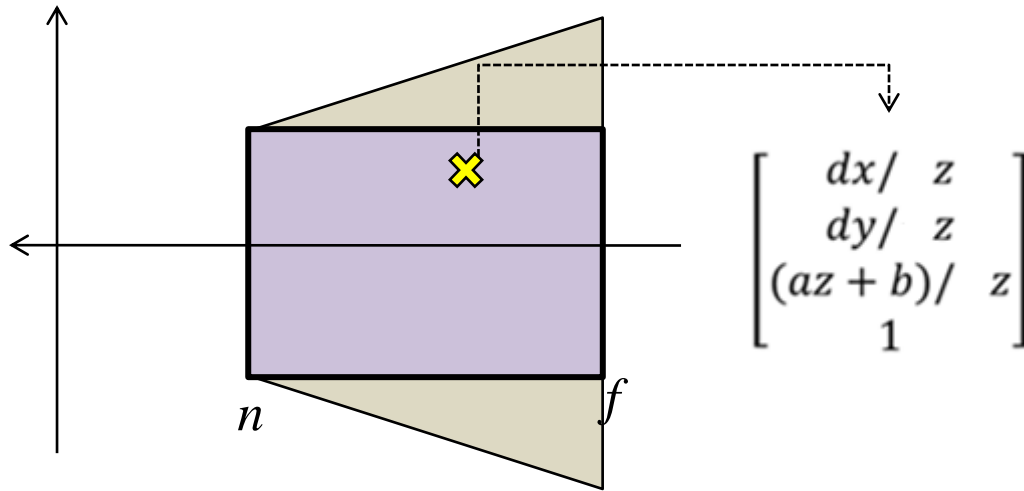

Perspective Projection (20/22)

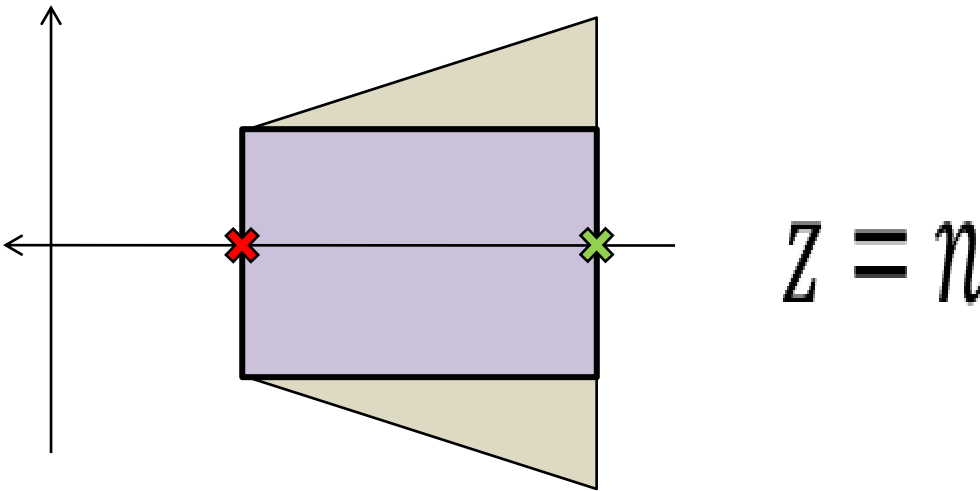

$z = n$

$z = f$

Perspective Projection (20/22)

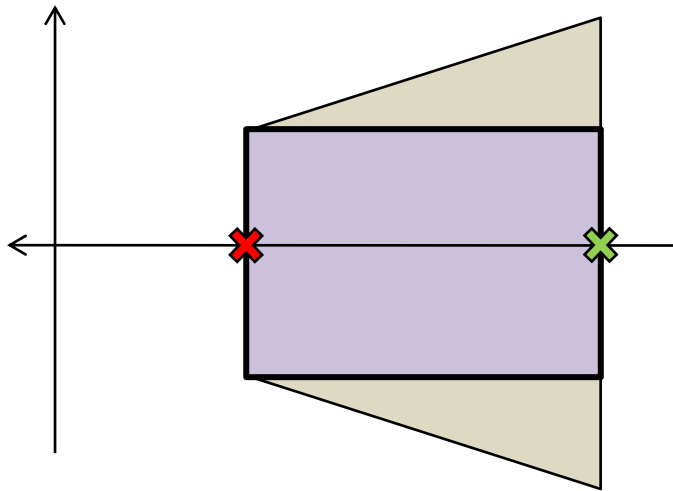

$$z = n$$

$$z = n$$

$$z = f$$

$$\begin{bmatrix} 0 \\ 0 \\ n \\ 1 \end{bmatrix}$$

$$\begin{bmatrix} 0 \\ 0 \\ f \\ 1 \end{bmatrix}$$

Perspective Projection (20/22)

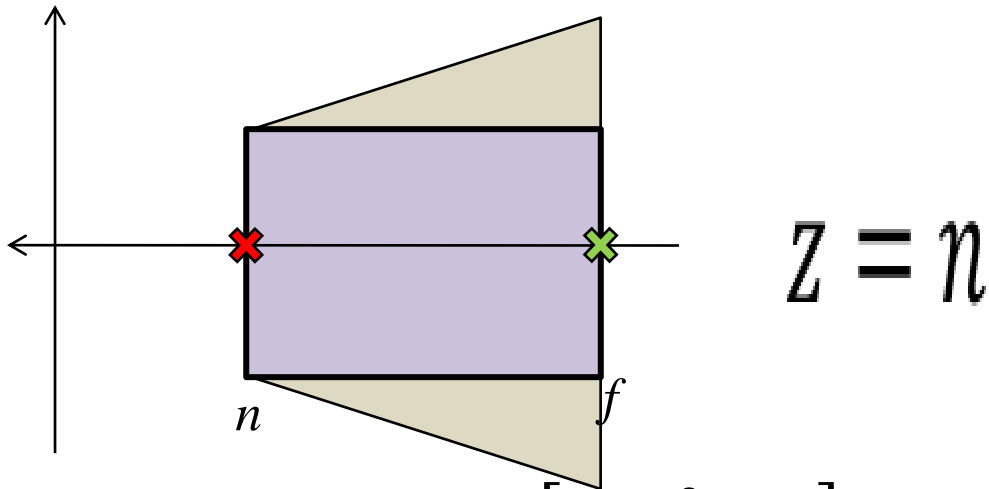

$$z = n \quad \begin{bmatrix} 0 \\ 0 \\ (an + b)/n \\ 1 \end{bmatrix} = \begin{bmatrix} 0 \\ 0 \\ n \\ 1 \end{bmatrix}$$

$$z = f \quad \begin{bmatrix} 0 \\ 0 \\ (af + b)/f \\ 1 \end{bmatrix} = \begin{bmatrix} 0 \\ 0 \\ f \\ 1 \end{bmatrix}$$

Perspective Projection (20/22)

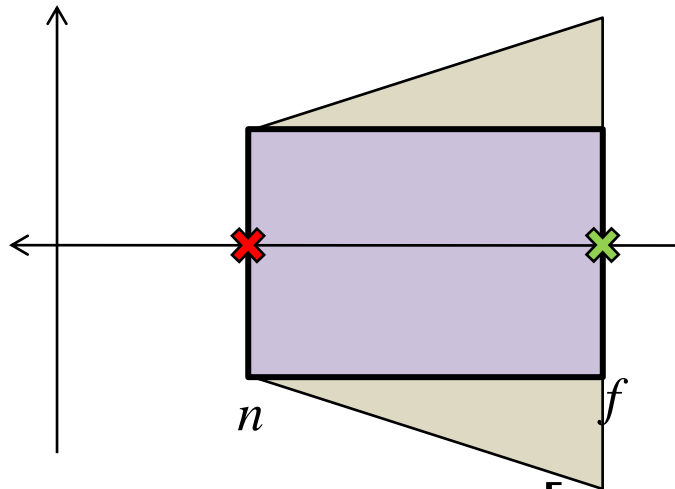

$$\begin{bmatrix} dx/z \\ dy/z \\ (az+b)/z \\ 1 \end{bmatrix}$$

$$a = (n+f)$$

$$b = -fn$$

$$z = n \quad \begin{bmatrix} 0 \\ 0 \\ (an+b)/n \\ 1 \end{bmatrix} = \begin{bmatrix} 0 \\ 0 \\ n \\ 1 \end{bmatrix}$$

Q: But how?

$$z = f \quad \begin{bmatrix} 0 \\ 0 \\ (af+b)/f \\ 1 \end{bmatrix} = \begin{bmatrix} 0 \\ 0 \\ f \\ 1 \end{bmatrix}$$

Perspective Projection (22/22)

$$P = \begin{bmatrix} d & 0 & 0 & 0 \\ 0 & d & 0 & 0 \\ 0 & 0 & a & b \\ 0 & 0 & -1 & 0 \end{bmatrix}$$

$$a = (n+f)$$

$$b = -fn$$

$$d = ?$$

perspective matrix: $P = \begin{bmatrix} n & 0 & 0 & 0 \\ 0 & n & 0 & 0 \\ 0 & 0 & n+f & -fn \\ 0 & 0 & 1 & 0 \end{bmatrix}$

Summary (1/6)

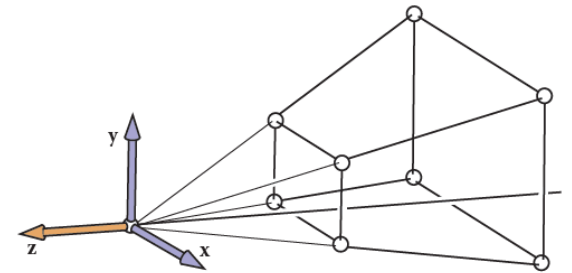

pers. view. vol.

Summary (2/6)

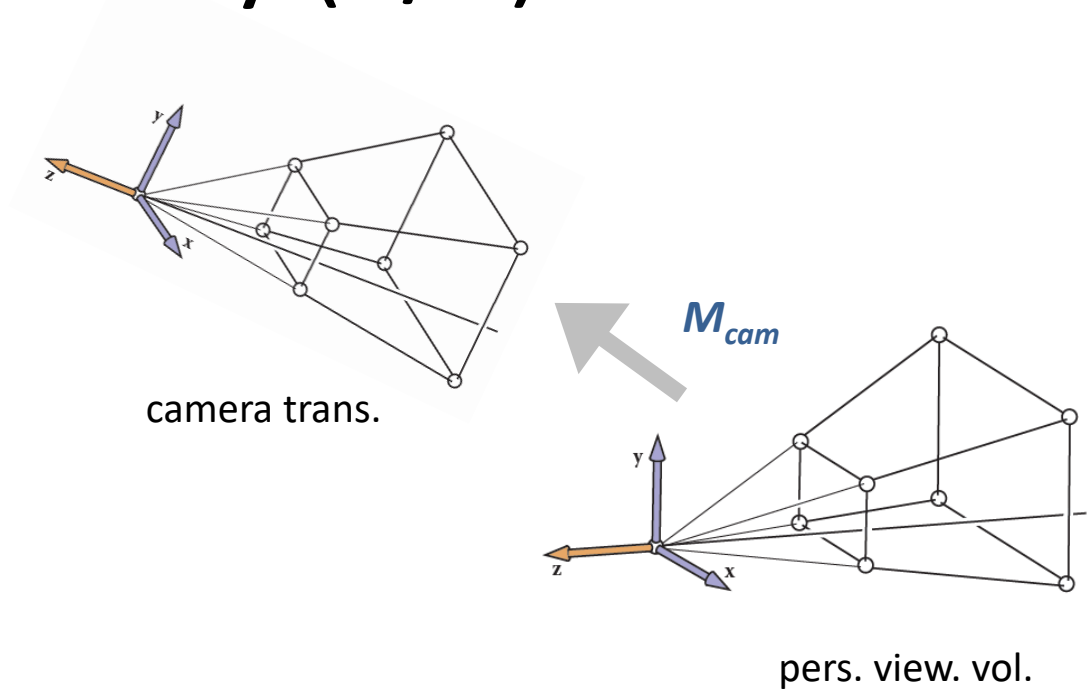

Summary (3/6)

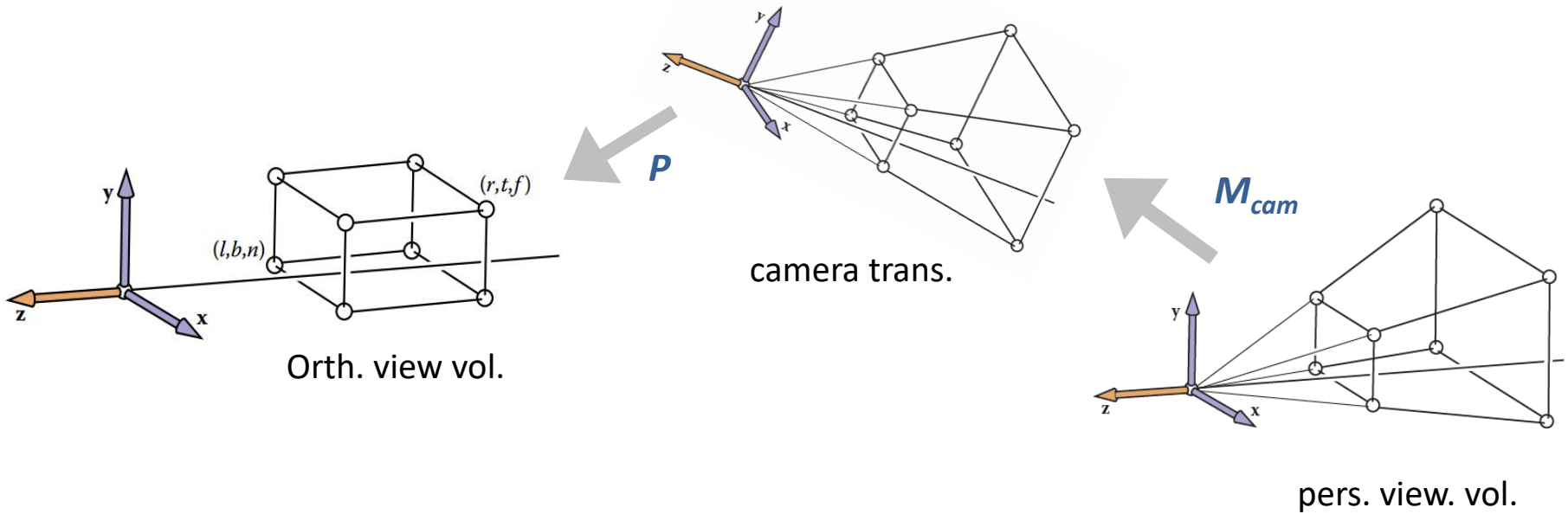

Summary (4/6)

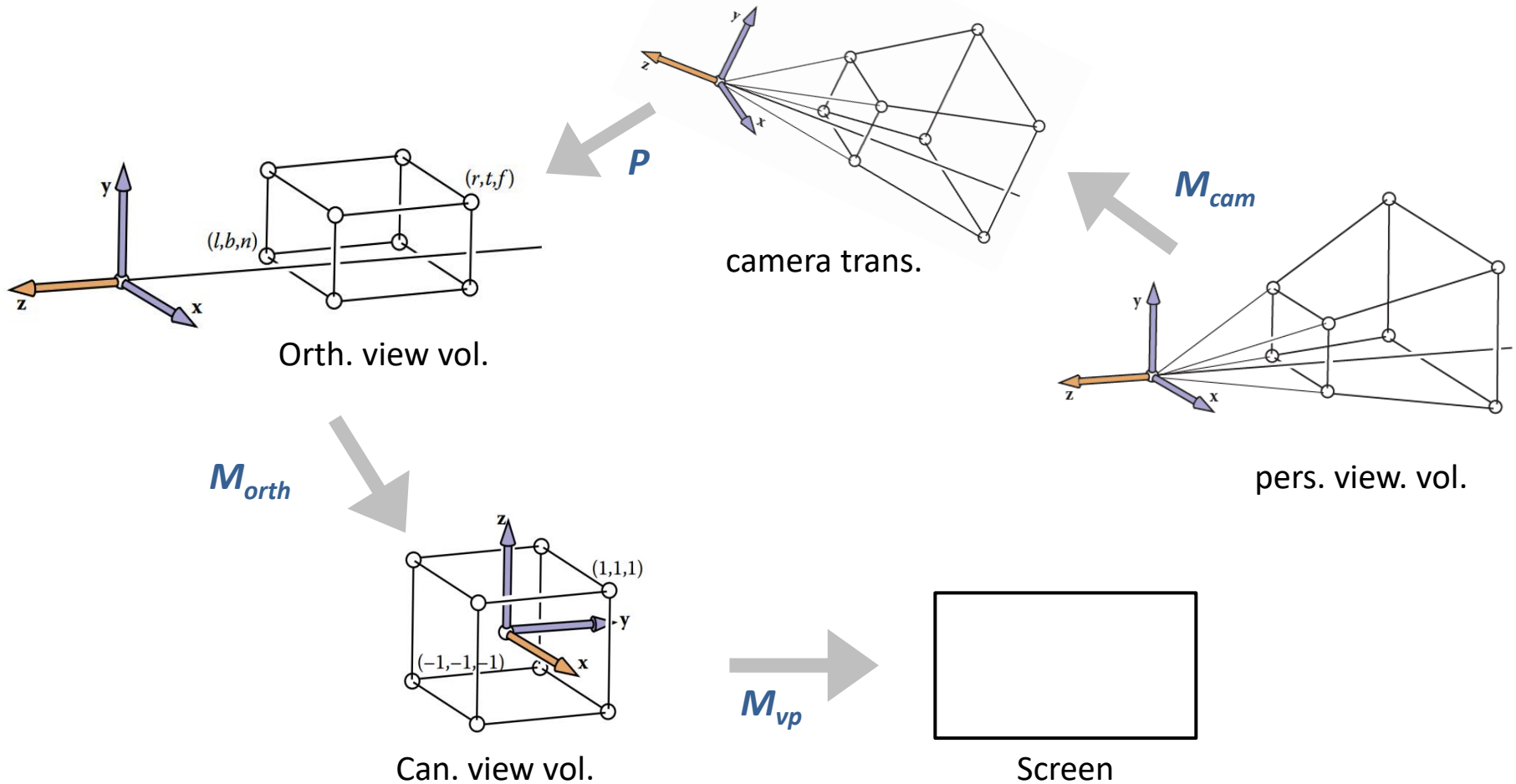

Summary (5/6)

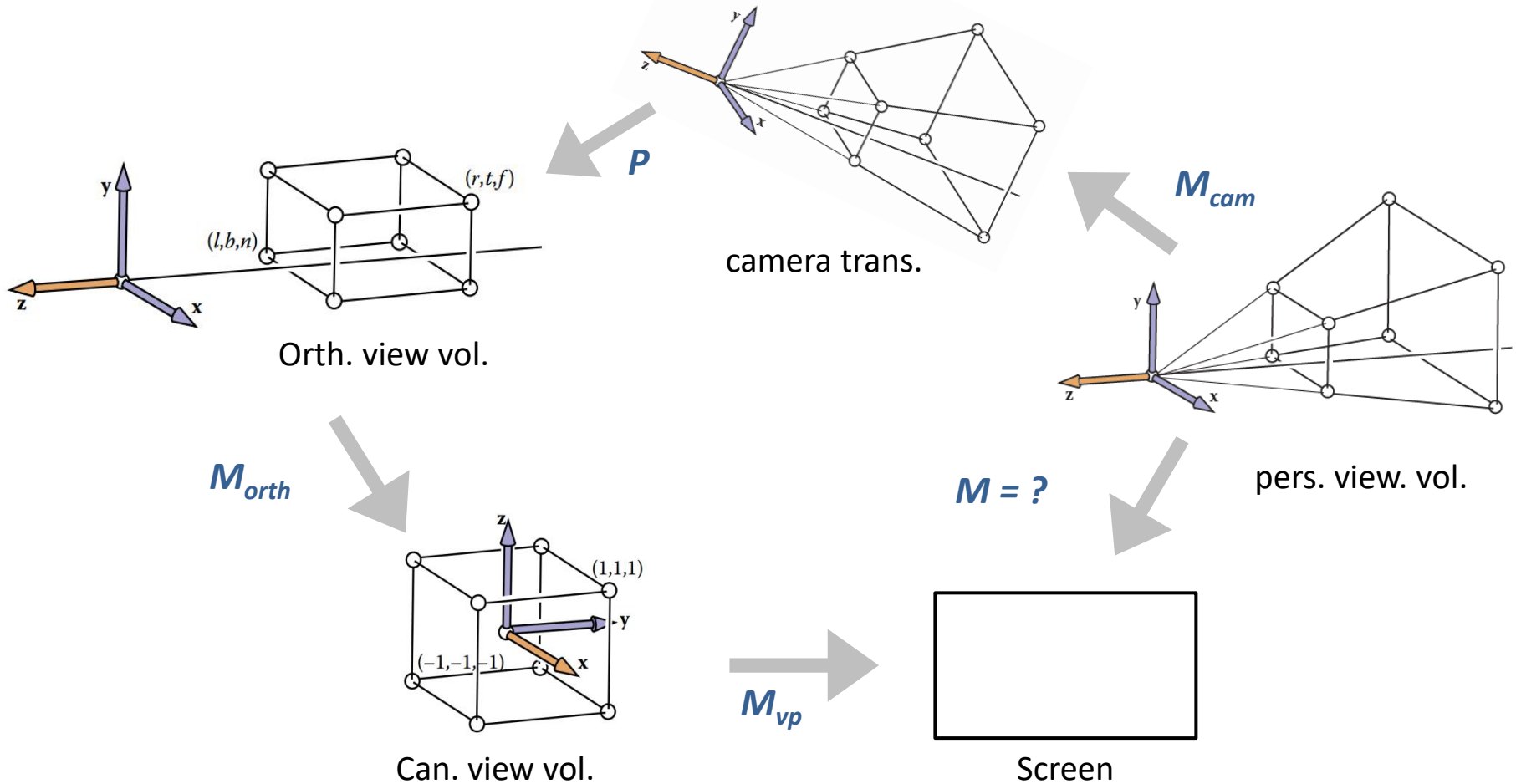

Summary (6/6)

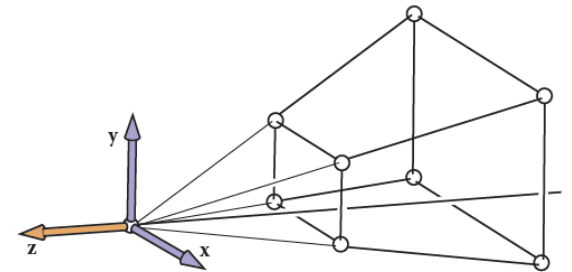

$$M = M_{vp} * M_{orth} * P * M_{cam}$$

$$M = M_{vp} * M_{per} * M_{cam}$$



Screen

Perspective Matrix (1/1)

$$\mathbf{M}_{\text{per}} = \mathbf{M}_{\text{orth}} \mathbf{P}$$

$$= \begin{bmatrix} \frac{2}{r-l} & 0 & 0 & -\frac{r+l}{r-l} \\ 0 & \frac{2}{t-b} & 0 & -\frac{t+b}{t-b} \\ 0 & 0 & \frac{2}{n-f} & -\frac{n+f}{n-f} \\ 0 & 0 & 0 & 1 \end{bmatrix} \begin{bmatrix} n & 0 & 0 & 0 \\ 0 & n & 0 & 0 \\ 0 & 0 & n+f & -fn \\ 0 & 0 & 1 & 0 \end{bmatrix}$$

$$= \begin{bmatrix} \frac{2n}{r-l} & 0 & \frac{l+r}{l-r} & 0 \\ 0 & \frac{2n}{t-b} & \frac{b+t}{b-t} & 0 \\ 0 & 0 & \frac{f+n}{n-f} & \frac{2fn}{f-n} \\ 0 & 0 & 1 & 0 \end{bmatrix} \quad \mathbf{M}_{\text{OpenGL}} = \begin{bmatrix} \frac{2|n|}{r-l} & 0 & \frac{r+l}{r-l} & 0 \\ 0 & \frac{2|n|}{t-b} & \frac{t+b}{t-b} & 0 \\ 0 & 0 & \frac{|n|+|f|}{|n|-|f|} & \frac{2|f||n|}{|n|-|f|} \\ 0 & 0 & -1 & 0 \end{bmatrix}$$

Perspective Transformation Chain (1/1)

1. Modeling transform: M_m
2. Camera Transformation: M_{cam}
3. Perspective: P
4. Orthographic projection: M_{orth}
5. Viewport transform: M_{vp}

$$\mathbf{p}_s = \mathbf{M}_{vp} \mathbf{M}_{orth} \mathbf{P} \mathbf{M}_{cam} \mathbf{M}_m \mathbf{p}_o$$

$$\begin{bmatrix} x_s \\ y_s \\ z_c \\ 1 \end{bmatrix} = \begin{bmatrix} \frac{n_x}{2} & 0 & 0 & \frac{n_x-1}{2} \\ 0 & \frac{n_y}{2} & 0 & \frac{n_y-1}{2} \\ 0 & 0 & 1 & 0 \\ 0 & 0 & 0 & 1 \end{bmatrix} \begin{bmatrix} \frac{2}{r-l} & 0 & 0 & -\frac{r+l}{r-l} \\ 0 & \frac{2}{t-b} & 0 & -\frac{t+b}{t-b} \\ 0 & 0 & \frac{2}{n-f} & -\frac{n+f}{n-f} \\ 0 & 0 & 0 & 1 \end{bmatrix} \begin{bmatrix} n & 0 & 0 & 0 \\ 0 & n & 0 & 0 \\ 0 & 0 & n+f & -fn \\ 0 & 0 & 1 & 0 \end{bmatrix} \mathbf{M}_{cam} \mathbf{M}_m \begin{bmatrix} x_o \\ y_o \\ z_o \\ 1 \end{bmatrix}$$

Code: *Orth. to Screen v.3 (1/2)*

Drawing many 3D lines with endpoints a_i and b_i :

```
Construct  $M_{vp}$ 
```

```
Construct  $M_{per}$ 
```

```
Construct  $M_{cam}$ 
```

```
 $M = M_{vp} * M_{per} * M_{cam}$ 
```

```
for each line segment  $(a_i, b_i)$  do:
```

```
     $p = M * a_i$ 
```

```
     $q = M * b_i$ 
```

```
    drawline  $(x_p/W_p, y_p/W_p, x_q/W_q, y_q/W_q)$ 
```

Code: *Orth. to Screen v.3 (2/2)*

Drawing many 3D lines with endpoints a_i and b_i :

```
Construct  $M_{vp}$ 
```

```
Construct  $M$ 
```

```
Cons
```

$$M = \begin{bmatrix} d & 0 & 0 & 0 \\ 0 & d & 0 & 0 \\ 0 & 0 & a & b \\ 0 & 0 & -1 & 0 \end{bmatrix} \begin{bmatrix} x \\ y \\ z \\ 1 \end{bmatrix} = \begin{bmatrix} dx \\ xy \\ az + b \\ -z \end{bmatrix} \sim \begin{bmatrix} dx/-z \\ dy/-z \\ (az + b)/-z \\ 1 \end{bmatrix}$$

```
for each line segment  $(a_i, b_i)$  do:
```

```
   $p = M * a_i$ 
```

```
   $q = M * b_i$ 
```

```
  drawline
```

$(x_p/W_p, y_p/W_p, x_q/W_q, y_q/W_q)$

Field-of-View (1/6)

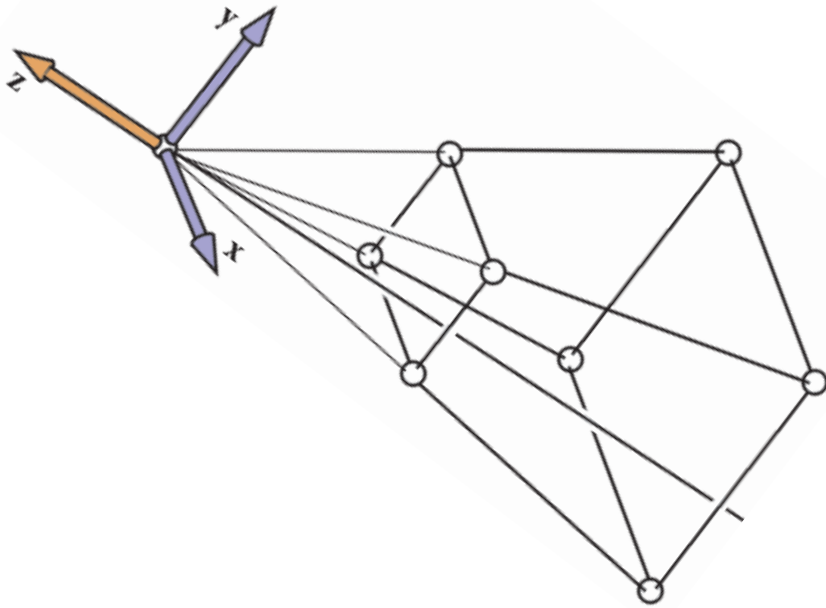

Field-of-View (2/6)

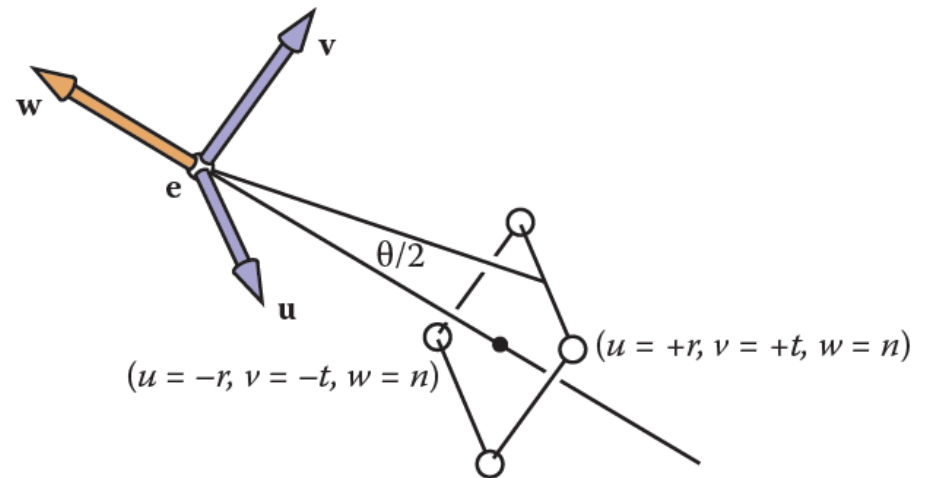
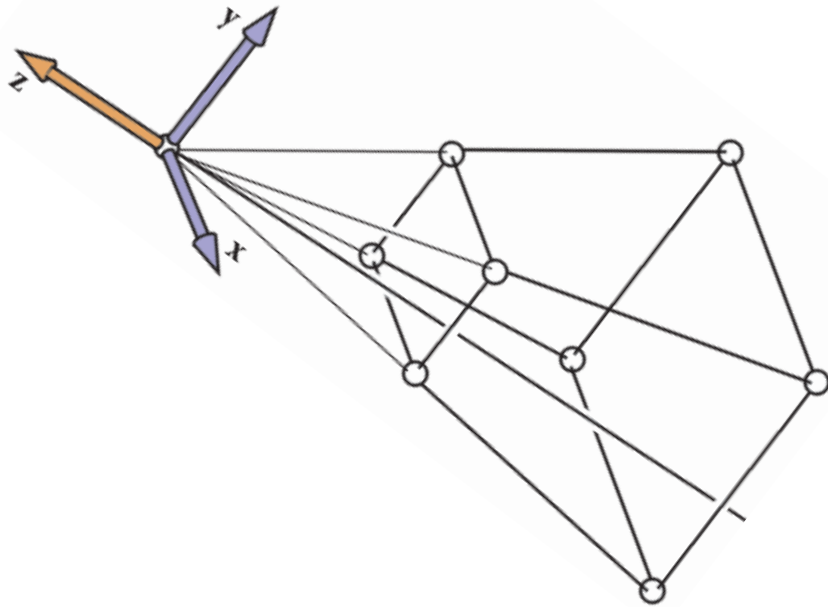

Field-of-View (3/6)

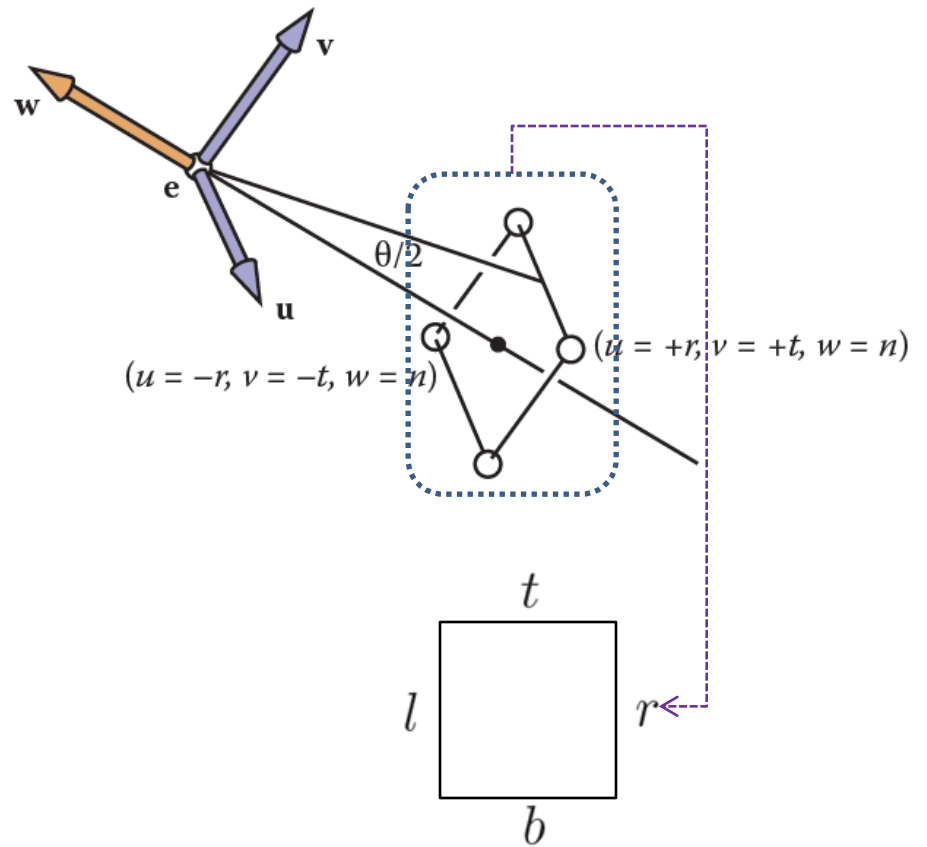
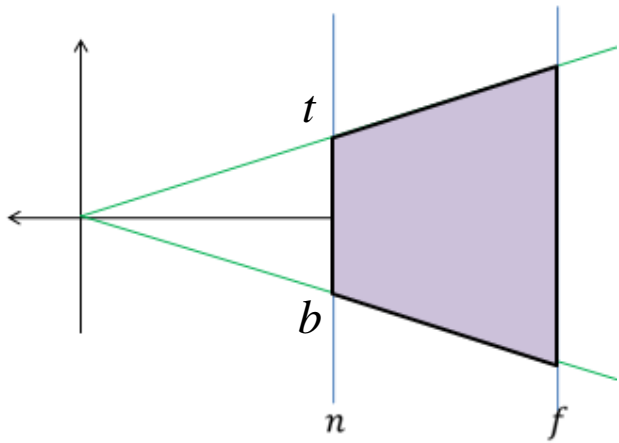

Field-of-View (4/6)

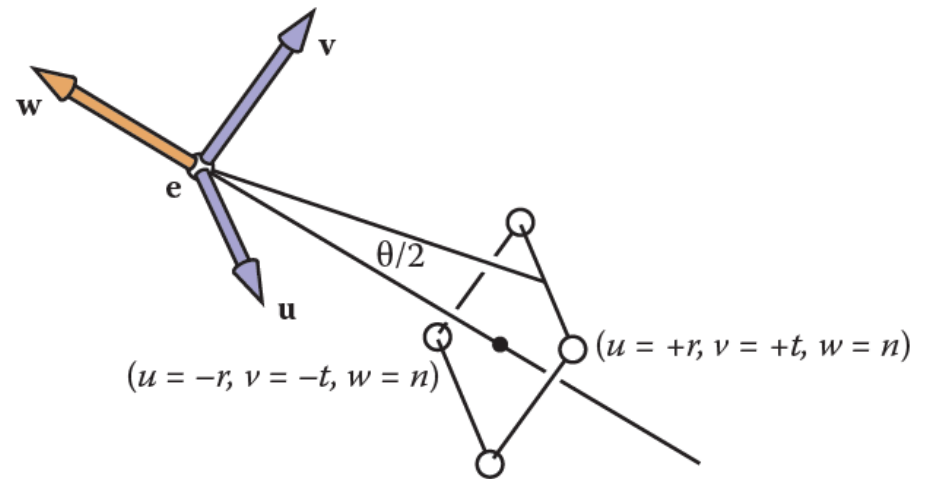
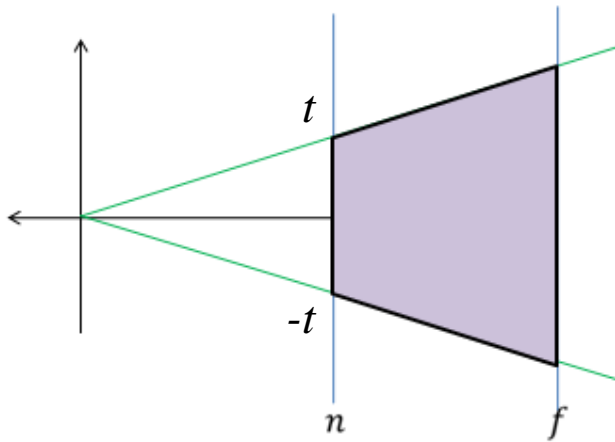

$$l = -r,$$

$$b = -t.$$

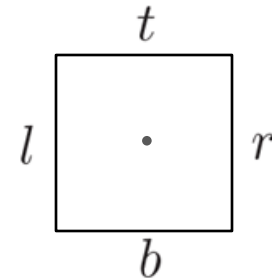

Field-of-View (5/6)

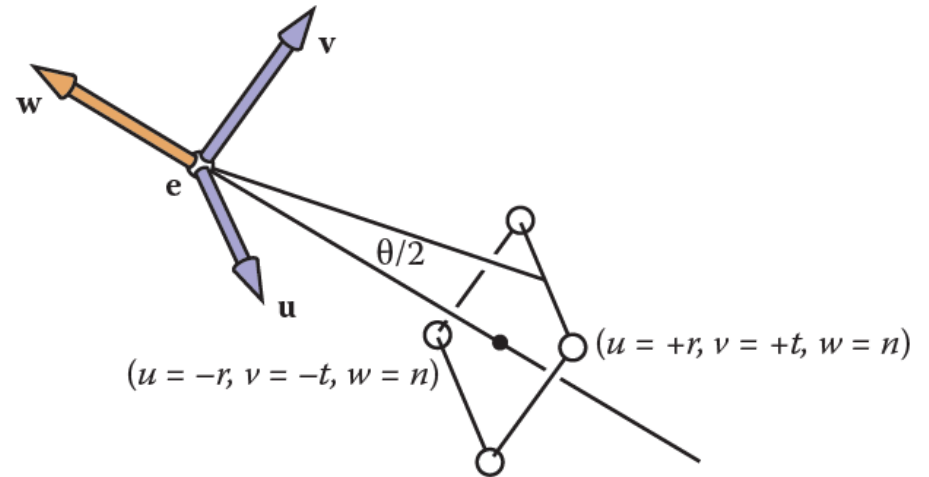
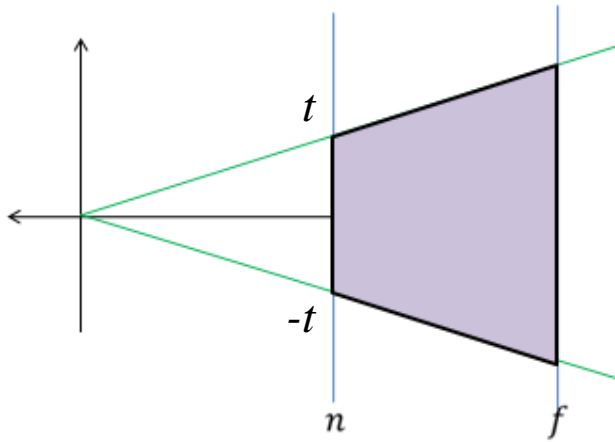

$$l = -r,$$

$$b = -t.$$

$$\tan \frac{\theta}{2} = \frac{t}{|n|}$$

Field-of-View (6/6)

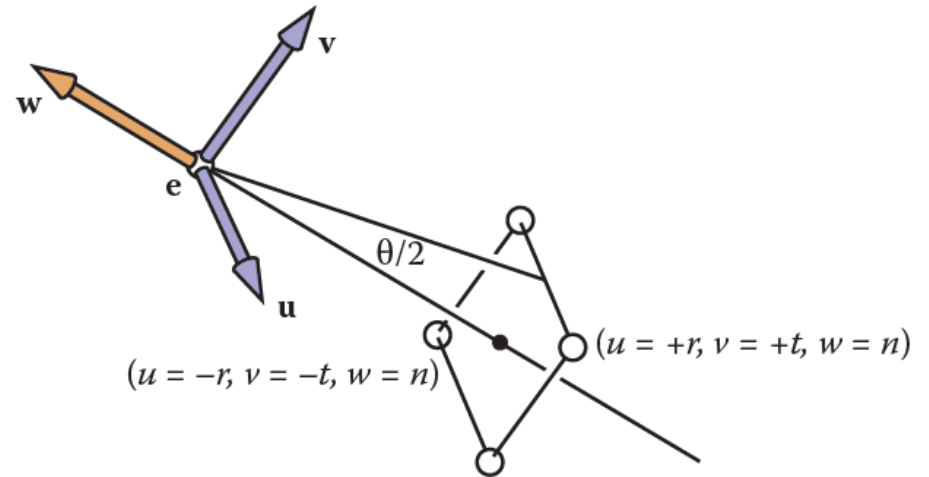
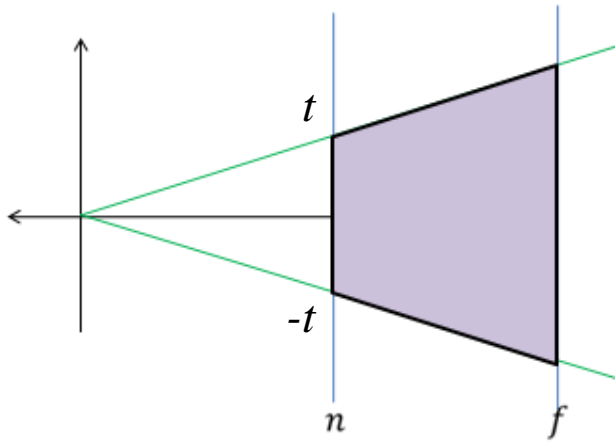

$$l = -r,$$

$$b = -t.$$

$$\tan \frac{\theta}{2} = \frac{t}{|n|}$$

Field-of-View (FoV)

Practice Problem (1/2)

- Show that, the M_{OpenGL} can be written as follows –

$$M_{\text{OpenGL}} = \begin{bmatrix} \frac{2|n|}{r-l} & 0 & \frac{r+l}{r-l} & 0 \\ 0 & \frac{2|n|}{t-b} & \frac{t+b}{t-b} & 0 \\ 0 & 0 & \frac{|n|+|f|}{|n|-|f|} & \frac{2|f||n|}{|n|-|f|} \\ 0 & 0 & -1 & 0 \end{bmatrix} = \begin{bmatrix} \frac{1}{\text{aspect} * \tan(\frac{fov}{2})} & 0 & 0 & 0 \\ 0 & \frac{1}{\tan(\frac{fov}{2})} & 0 & 0 \\ 0 & 0 & -\frac{far + near}{far - near} & -\frac{2 * far * near}{far - near} \\ 0 & 0 & -1 & 0 \end{bmatrix}$$

here, $\text{aspect} = \text{ratio of the width to the height of the view.}$ $\text{vol.} = ?$

Practice Problem (2/2)

- Derive all the matrices (using your own words):
 - a) M_{vp}
 - b) M_{orth}
 - c) M_{cam}
 - d) P and M_{per}
- Rotate a camera by -45 degree along x-axis with the eye position at 0, 0.5, -4. For a point $P_{xyz} \equiv (0, 0, 3)$, $P_{uvw} \equiv ?$
- Exercise:
 - 1, 7, 8, 10